

CATEGORY	DESCRIPTION	P/N #
CONNECTOR	2.0 BATTERY 8PIN	BA08EM-DB9G1-0300

REV.	ECN NO	DESCRIPTION	REVISED	DATE
R01		NEW RELEASE	XSY	2009.07.15
A01	ECN090731001	1.更改HARPOON尺寸由2.84變更為2.50 2.更改CAP外形,CAP的塑膠材質由PA9T變更為LCP 3.HOUSING的塑膠材質由PA9T變更為LCP	GMC	2009.07.31

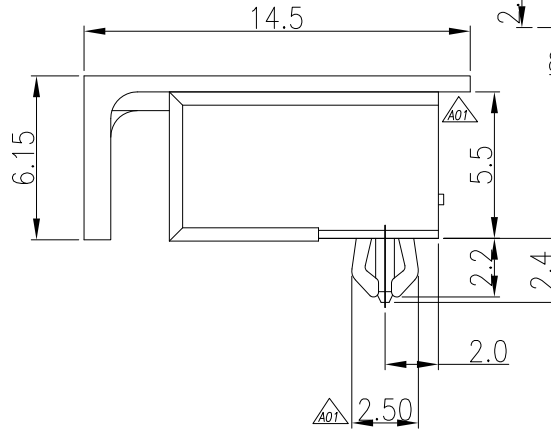
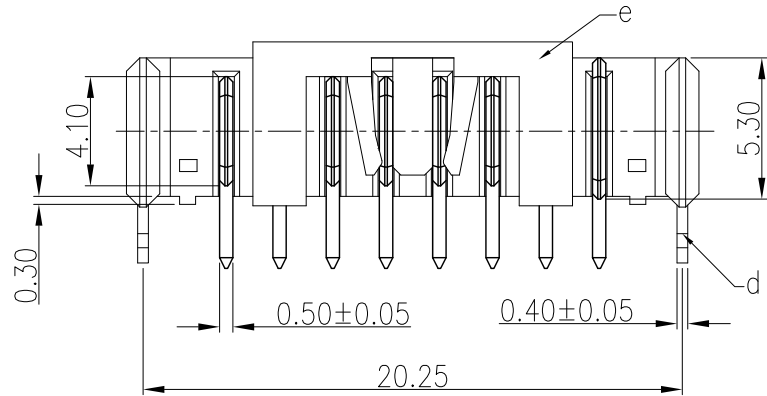
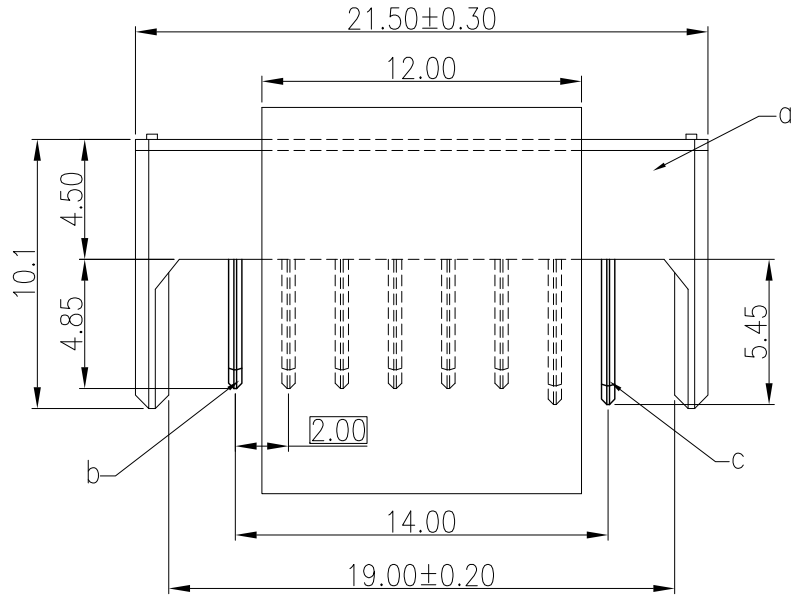

SPECIFICATIONS

- CONTACT CURRENT RATING: 2 Amperes.MAX.
- WITHSTANDING VOLTAGE: AC 500V MIN./60S
- INSULATION RESISTANCE: 500 MΩ
- CONTACT RESISTANCE: 50 mΩ MAX.
- VOLTAGE RATING: 50V DC
- TEMPERATURE: -25°C TO +90°C.
- SOLDER HEAT RESISTANCE:WAVE SOLDERING 260° 10sec.
- TO CONFORM TO THE "SoNY" DIRECTIVE.
- GREEN PRODUCT IDENTIFICATION LABEL IN PACKING: **G.P. PASS**

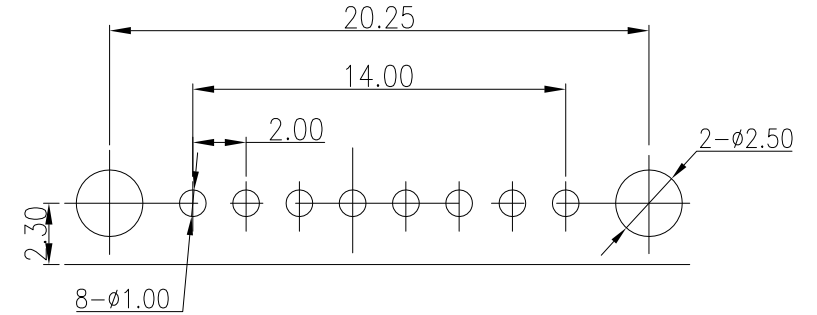

RECOMMEND PCB LAYOUT  
PCB THICKNESS:1.20mm.  
PCB LAUOUT TOLERANCE:±0.05mm.

e	CAP	1	LCP UL94V-0 $\Delta$ A01	BLACK	
d	HARPOON	2	BRASS	Tin PLATING	
c	LONG CONTACT	2	BRASS	Gold Flash Plating	
b	SHORT CONTACT	6	BRASS	Gold Flash Plating	
a	HOUSING	1	LCP UL94V-0 $\Delta$ A01	BLACK	
NO.	PART NAME	Q'TY	MATERIAL	PLATING & COLOR	Remark

UNLESS OTHERWISE SPECIFIED TOLERANCES	SCALE:1/1	UNIT: mm	DWG.NO: WI-061-505	
	SIZE: A4	PAGE: 10F1		REV:A01
DECIMALS: X :±0.5 X.X :±0.3 X.XX :±0.2	ANGLES: X :±2° X.X :±1°	APPROVED BY WYX	CHECKED BY PJ	PREPARED BY GMC
<b>CUSTOMER COPY</b>				